



UNIQ L.E.D. Lighting

2150 Boggs Rd. Suite 350 Duluth, Ga. 30096

PH. 770-418-1600 Fx. 770-795-9977 (Uniqtechinc.com)



LED Recessed Dome/Door Light

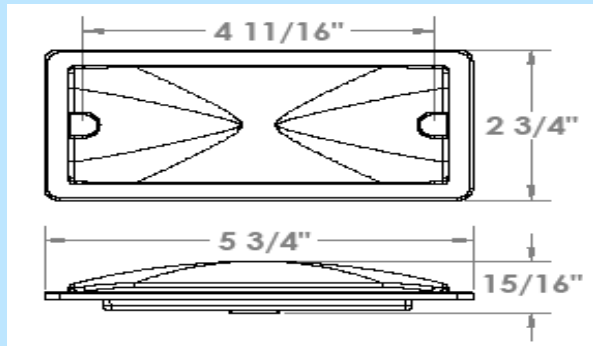

Mechanical Design



- Low power consumption, **GREEN** design
- Hi-Reliability, Long Life Span
- Lamp contains 10 Super-Bright LEDs
- Polycarbonate lens attached to housing with screws
- Available with plated steel and chromed steel housing
- Lamps can be terminated per customer specification
- Mounting hardware provided

Mechanical Specifications	PN: UQ-22572		
	UQ-22572 Plated		UQ-22572N Chrome
Available Faces	10 LED White		10 LED White
Wire Termination	Per Customer Specification		Per Customer Specification
Dimensions	Length	Width	Height
	5 3/4"	2 3/4"	15/16"
Electrical Specifications			
Voltage	8-14VDC		8-14VDC
Power Consumption @ 12VDC	Super Bright		
	1.5 Watt @ 0.125A		1.5 Watt @ 0.125A
Regulatory Approvals			
	N/A		N/A

