



# UNIQ L.E.D. Lighting

2150 Boggs Rd. Suite 350 Duluth, Ga. 30096

PH. 770-418-1600 Fx. 770-795-9977 (Uniqtechinc.com)

## 6" LED Dome Lamp

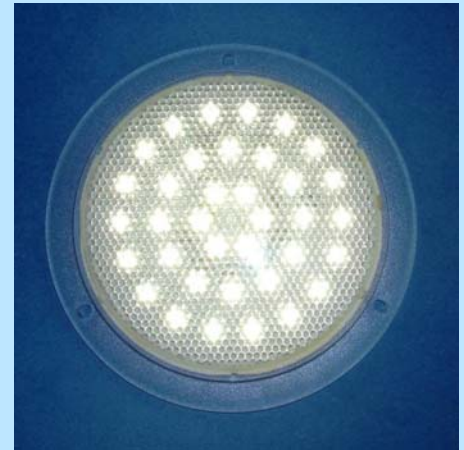
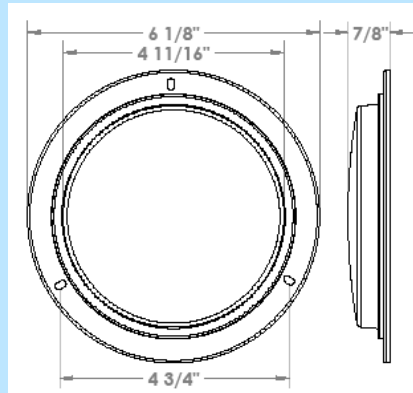
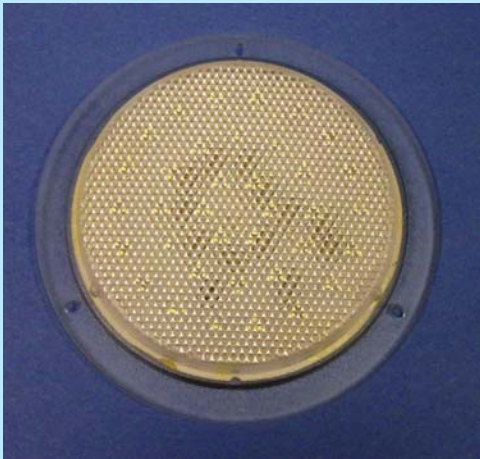

### Mechanical Design

- Low power consumption, **GREEN** design
- Hi-Reliability, Long Life Span
- Lamp face contains either 24 or 36 Super-Bright LEDs
- A sealed polycarbonate lens and acrylic base forms a dustproof/corrosion proof unit which mounts using three screws
- High Bright LEDs illuminate a large area
- Lamps can be terminated per customer specification
- Available with external dimming switch
- Mounting hardware provided

Mechanical Specifications	PN: UQ-22751		
	UQ-22751NFC	UQ-22751FC	UQ-22751FC-1
Available Faces	White 24 LED	White 36 LED	White 36 LED
Wire Termination	Per Customer Specification	Per Customer Specification	Per Customer Specification
Dimensions	Diameter	Depth	Mounting Holes
	6 1/8"	7/8"	1/8"
Electrical Specifications			
Voltage	12VDC	12VDC	24VDC
Power Consumption @ 12VDC	Bright	Bright	Bright
	1.2 Watt @ 0.1A	1.8W @ 0.15A	1.8W @ 0.15A
Regulatory Approvals			
	N/A		

